

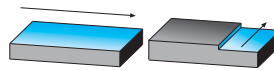

## Fresa ad inserti per spianatura e spallamenti a 89,5° con attacco a manicotto

Fresa ad inserti per spianare ed eseguire spallamenti a 89,5° con attacco a manicotto, corpo della fresa **con passaggio interno del lubrorefrigerante**, geometria positiva utilizzabile su macchine con potenze medie.

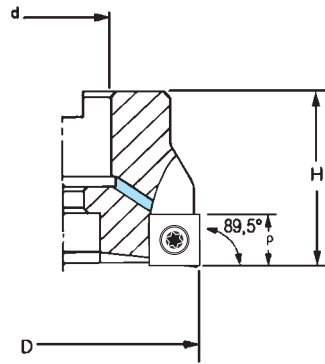

Codice	€	Dimensioni				
		D (mm)	d (H7) (mm)	H (mm)	p (mm)	Z
A581700040	◆	40	16	40	6	6
A581700050	◆	50	22	40	6	7
A581700063	◆	63	22	40	6	8

Ricambi		
Inserto	Vite	Giravite
SPMT 0603	A910350015	A559250070

Inserti: vedi pag. 400/401/402/403/404/405.



## Fresa ad inserti per spianatura e spallamenti a 89,5°

Fresa ad inserti per spianare ed eseguire spallamenti a 89,5° con codolo cilindrico e piano di trascinamento DIN 1835B, corpo della fresa **con passaggio interno del lubrorefrigerante**, geometria positiva utilizzabile su macchine con potenze medie.

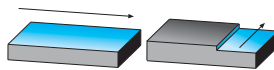
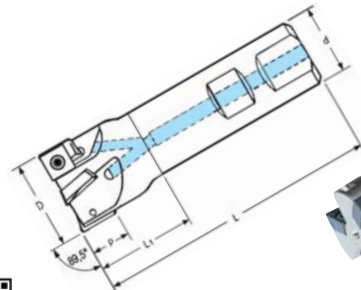

Codice	€	Dimensioni					
		D (mm)	d (h6) (mm)	L (mm)	L1 (mm)	p (mm)	Z
A581750025	◆	25	25	100	44	9	2
A581750032	◆	32	32	110	50	9	3
A581750040	◆	40	32	115	45	9	4

Ricambi		
Inserto	Vite	Giravite
SPMT 09T3	A910350027	N202350150

Inserti: vedi pag. 400/401/402/403/404/405.