

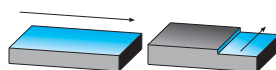

Fresa ad inserti per spianatura e spallamenti a 89,5° con attacco a manicotto

Fresa ad inserti per spianare ed eseguire spallamenti a 89,5° con attacco a manicotto, corpo della fresa **con passaggio interno del lubrorefrigerante**, geometria positiva utilizzabile su macchine con potenze medie.

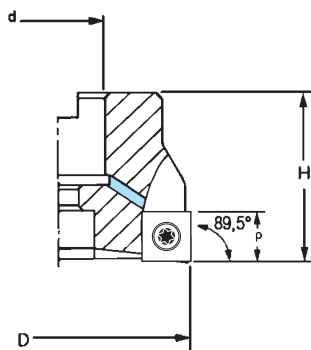

Ricambi		
Inserto	Vite	Giravite
SPMT 09T3	A910350027	N202350150

Inserti: vedi pag. 400/401/402/403/404/405.

Codice	€	Dimensioni				
		D (mm)	d (H7) (mm)	H (mm)	p (mm)	Z
A581800040	◆	40	16	40	9	4
A581800050	◆	50	22	40	9	5
A581800063	◆	63	22	40	9	6
A581800080	◆	80	27	50	9	7
A581800100	◆	100	32	50	9	8



Fresa ad inserti per spianatura e spallamenti a 90° con attacco a manicotto

Fresa ad inserti per spianare ed eseguire spallamenti a 90°, corpo della fresa **con passaggio interno del lubrorefrigerante**, geometria positiva utilizzabile su macchine con potenze medie.

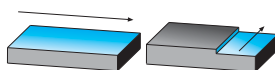
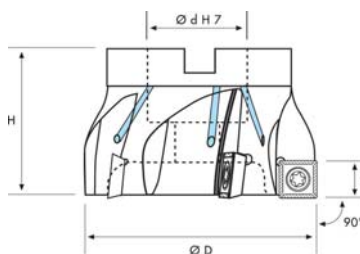

Ricambi		
Inserto	Vite	Giravite
SDMT 1205	A910350050	N202350150

Inserti: vedi pag. 400/401/402/403/404/405.

Codice	€	Dimensioni				
		D (mm)	d (H7) (mm)	H (mm)	p (mm)	Z
A580150040	◆	40	16	45	10,5	4
A580150050	◆	50	22	40	10,5	5
A580150063	◆	63	22	40	10,5	6
A580150080	◆	80	27	50	10,5	6
A580150100	◆	100	32	50	10,5	8
A580150125	◆	125	40	63	10,5	9