

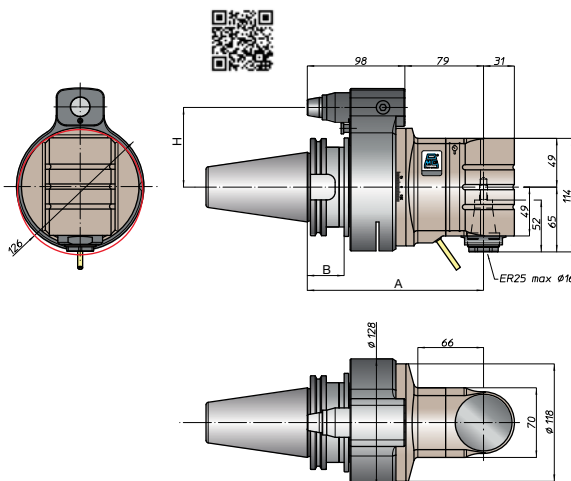

Testa ad angolo

Testa ad angolo in acciaio ricavata dal pieno, corpo trattato con niploy, trattamento anticorrosione, che garantisce alta protezione contro la ruggine, lubrificanti aggressivi e acidi, cuscinetti obliqui in classe di precisione ABEC 7/9, ingranaggi Gleason con evolvente rettificato, massime performance e minori vibrazioni.



Codice	€	Attacco	N° giri max (gir/min)	Pinza ER	Rapporto	Ø max foratura (mm)	Ø max maschiatura (M)	A (mm)	B (mm)	H (mm)
C99030005	---	40-DIN 69871	5000	25	1÷1	16	12	172	35	65
C990300010	---	50-DIN 69871	5000	25	1÷1	16	12	177	35	80
C990300015	---	MAS BT40	5000	25	1÷1	16	12	172	35	65
C990300020	---	MAS BT50	5000	25	1÷1	16	12	185	45	80
C990300025	---	HSK-A 63	5000	25	1÷1	16	12	181	44	65



Testa ad angolo

Testa ad angolo in acciaio ricavata dal pieno, corpo trattato con niploy, trattamento anticorrosione, che garantisce alta protezione contro la ruggine, lubrificanti aggressivi e acidi, cuscinetti obliqui in classe di precisione ABEC 7/9, ingranaggi Gleason con evolvente rettificato, massime performance e minori vibrazioni. Adduttore lubrificante interno max 70 Bar.

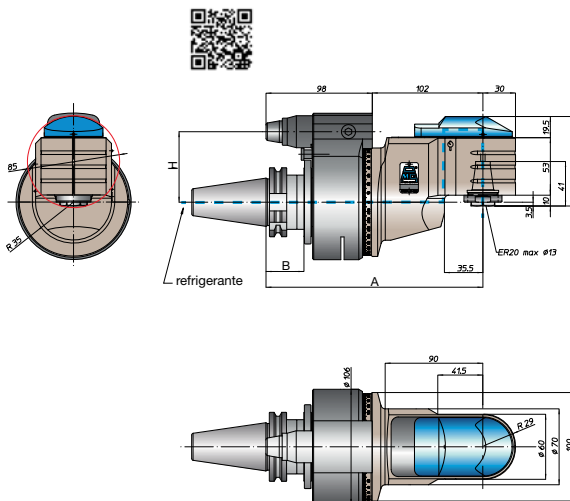

Codice	€	Attacco	N° giri max (gir/min)	Pinza ER	Rapporto	Ø max foratura (mm)	Ø max maschiatura (M)	A (mm)	B (mm)	H (mm)
C990350005	---	40-DIN 69871	4500	20	1÷1	13	10	200	35	65
C990350010	---	50-DIN 69871	4500	20	1÷1	13	10	200	35	80
C990350015	---	MAS BT40	4500	20	1÷1	13	10	200	35	65
C990350020	---	MAS BT50	4500	20	1÷1	13	10	208	45	80
C990350025	---	HSK-A 63	4500	20	1÷1	13	10	209	44	65