



Frese in metallo duro • Frese per stampi • Fresatura modulare • Seghe circolari • Seghe a tazza • Lame • Barrette • **Frese ad inserti** • Punte ad inserti • Inserti e ricambi • Portainseriti per filettare, troncarea e scanalare • Godronatura • Brocciatura/Stozzatura • Utensili saldobrasati • Lubrorefrigeranti e sistemi

TKn **Fresa ad inserti per alti avanzamenti con attacco a manicotto**

Fresa ad inserti per alti avanzamenti con attacco a manicotto, corpo della fresa **con passaggio interno del lubrorefrigerante**.

Utilizzabile per esecuzione di: fresatura frontale, ad angolo, elicoidale, a tufo, di profili, di tasche e di cave.

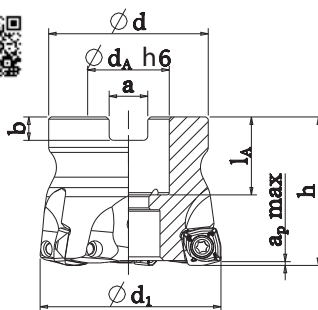
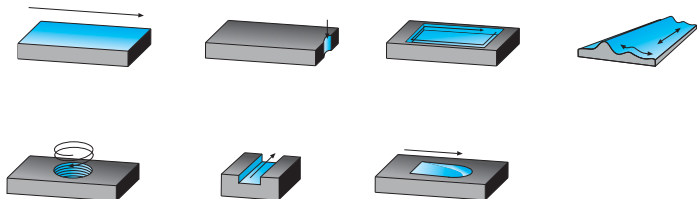

Ricambi		
Inserto	Vite	Giravite
XOLT 130410SR-HCM CTC230	A919050015	N202350200
XOLT 130410SR-HCM CTC230	A919050015	N202350200

Codice	€	Dimensioni					
		d1 (mm)	dA h6 (mm)	h (mm)	d n(mm)	a (mm)	Z
A587150050	◆	50	22	40	43	2	4
A587150063	◆	63	22	40	48	2	5

Ricambi: vedi pag. 529/530/531/532.

Codice	€	Pz	Foto	Denominazione	Figura	Dimensioni (mm)					Classi metallo duro														
						l	d	s	d1	r	Non rivestiti		Rivestiti				Cermet								
											NK 15	NP 25	RP 200	RP 300	RK 300	RK 400		KTP 230	TIN	TIALN	CX 55				
A934100525	◆	10		XOLT 130410SR-HCM		-	13	4,76	5,5	1															

Tabella materiali e parametri di utilizzo consigliati vedi pag. 337/338/339/340/341/342/343/344/345.



Noi vendiamo soluzioni